

## *Overview Product Range*

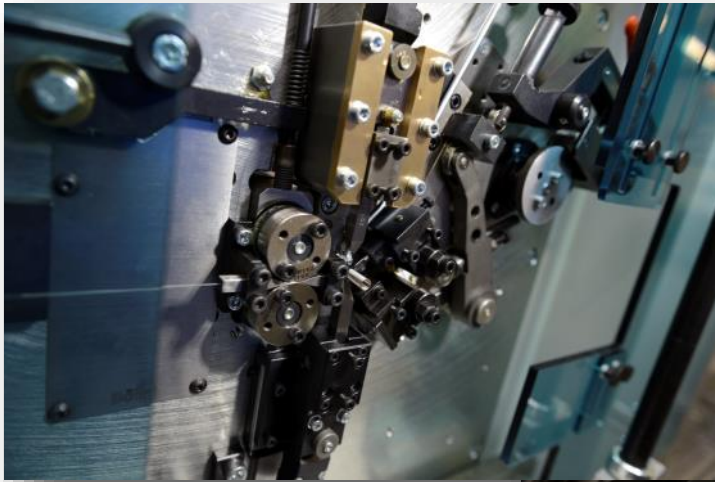

<b>Spring load tester:</b>	Manual testers 10,000 N up to 5 kN Motor driven testers 1 kN up to 50 kN PC controlled testers 50 N up to 200 kN
<b>Torsion spring tester:</b>	Manual testers 100 Nmm up to 150 Nm PC controlled testers 100 Nmm up to 150 Nm
<b>Test and scragging units:</b>	Motor drive 10,000 N up to 200 N Indexing table 1.000 N up to 5.000 N Hydraulic above 5.000 N
<b>Spring coiler:</b>	Comp. springcoiler 0,1 - 0,8 mm wire dia. Torsion springcoiler 0,2 - 4 mm wire dia.
<b>Grinding machine:</b>	Addition to coilers and feedingsystems
<b>Packing machines:</b>	Tray packing max. 3600 parts per hour Plastic sheet wrapping max. 3600 parts per hour storage magazine, hose packing
<b>Robot loading devices:</b>	For throughfeed grinding For cycled loading plates
<b>Feeding technology:</b>	Conveyors, drum feeders, bowl feeders, spring detanglers, automatic spring feeding systems
<b>Swift for coils:</b>	0,1 mm - 5 mm wire diameter Weight of coils: 80 kg, 150 kg, 300 kg, 500 kg, 700 kg
<b>Drum decoiler:</b>	For various drumsizes
<b>Strip material decoilers:</b>	Weight of coils: 80 kg, 600 kg
<b>Tempering furnace:</b>	Different sizes

***Automatic assembly machines and customer specific solutions, on request.***

***We will be pleased to advise you!***

**Klaus Böhm Elektronik GmbH**

Germanenstraße 24

72768 Reutlingen

Tel.: +49 7121 515395-0

Fax: +49 7121 515395-23

[www.boehmelektronik.de](http://www.boehmelektronik.de)

[mail@boehmelektronik.de](mailto:mail@boehmelektronik.de)



# Spring load tester WG-3



**Load tester WG-3  
available with specified load ranges:**

Load range 0 - 10 Newton	Resolution: 0,0001 N
Load range 0 - 50 Newton	Resolution: 0,001 N
Load range 0 - 100 Newton	Resolution: 0,001 N
Load range 0 - 200 Newton	Resolution: 0,001 N

Also available with other load cells.

Max. length for compress springs 100 mm. Max. length for tension springs 150 mm.

The tester WG-3 has two guides with 4 bearings. The movement of the testplates is manual with a lever and has an additional fine adjustment screw. Two length stops can be set up for batch tests of springs. The TFT Touchscreen unit has a RS 232 data output to give the load values to a PC or SPC system. The length measurement by an incremental ruler has a resolution of 0,01 mm. The testplates have a diameter of 45 mm and are adjustable in parallelity. The deflection of the loadcell and the frame is automatically compensated.

# Spring load tester WG-3D



## Load tester WG-3D available with specified load ranges:

Load range 0 - 10 Newton	Resolution: 0,0001 N
Load range 0 - 50 Newton	Resolution: 0,001 N
Load range 0 - 100 Newton	Resolution: 0,001 N
Load range 0 - 200 Newton	Resolution: 0,001 N

Also available with other load cells. Retrofit is also possible.

Max. length for compress springs 100 mm. Max. length for tension springs 150 mm.

The tester WG-3D has two guides with 4 bearings. The movement of the testplates is manual with a lever and has an additional fine adjustment screw. Testplates dia. 45 mm. Tests of free length, block-length, load at length, length at load, rate, load/length and rate/length diagramm are possible.

The results can be archived or exported in Excel format to other CAQ systems.

# Spring load tester WG-4



**Load tester WG-4  
available with specified load ranges:**

Load range 0 - 100 Newton	Resolution: 0,001 N
Load range 0 - 200 Newton	Resolution: 0,001 N
Load range 0 - 500 Newton	Resolution: 0,01 N

Also available with other load cells.

Max. length for compress springs 250 mm. Max. length for tension springs 300 mm.

The tester WG-4 has two guides with 4 bearings. The movement of the testplates is manual with a lever and has an additional fine adjustment screw. Two length stops can be set up for batch tests of springs. The TFT Touchscreen unit has a RS 232 data output to give the load values to a PC or SPC system. The length measurement by an incremental ruler has a resolution of 0,01 mm. The testplates have a diameter of 45 mm and are adjustable in parallelity.

# Spring load tester WG-4D



## Load tester WG-4D available with specified load ranges:

Load range 0 - 100 Newton	Resolution: 0,001 N
Load range 0 - 200 Newton	Resolution: 0,001 N
Load range 0 - 500 Newton	Resolution: 0,01 N

Also available with other load cells. Retrofit is also possible.  
Max. length for compress springs 250 mm. Max. length for tension springs 300 mm.

The tester WG-4D has two guides with 4 bearings. The movement of the testplates is manual with a lever and has an additional fine adjustment screw. Testplates dia. 50 mm. Tests of free length, block-length, load at length, length at load, rate, load/length and rate/length diagramm are possible. The results can be archived or exported in Excel format to other CAQ systems.

# Spring load tester WG-11



**Load tester WG-11  
available with specified load ranges:**

Load range 0 - 1.000 Newton	Resolution: 0,01 N
Load range 0 - 2.000 Newton	Resolution: 0,01 N
Load range 0 - 5.000 Newton	Resolution: 0,1 N

Also available with other load cells.

Max. length for compress springs 570 mm. Max. length for tension springs 490 mm.

The spring-tester WG 11 is for the test of compression - and tension springs. The moveable testplate is guided by two bearings. The motor drives two precision ball screws which move the upper testplate and has an absolute length measuring system. The upper testplate can be replaced quickly by drilled plates for testing springs on a pin or tension spring hooks. The testplates have a diameter of 95 mm, option: 150 mm.

The testspeed and the testlengths are programmed at the touchscreen display. Up to three testlengths can be programmed in automatic mode. The results are displayed on the touchpanel and can be transferred to a PC by the data-output.

In manual mode the testplate can be moved by arrow-keys or direct input of the testlength.

# Spring load tester WG-29



**Load tester WG-29  
available with specified load ranges:**

Load range 0 - 10.000 Newton Resolution: 1 N  
Load range 0 - 20.000 Newton Resolution: 1 N

Also available with other load cells.

Max. length for compress springs 770 mm. Max. length for tension springs 670 mm.

The spring-tester WG 29 is for the test of compression - and tension springs. The moveable testplate is guided by two bearings. The motor drives two precision ball screws which move the upper testplate and has an absolute length measuring system. The upper testplate can be replaced quickly by drilled plates for testing springs on a pin or tension spring hooks. The testplates have a diameter of 250 mm.

The testspeed and the testlengths are programmed at the touchscreen display. Up to three testlengths can be programmed in automatic mode. The results are displayed on the touchpanel and can be transferred to a PC by the data-output.

In manual mode the testplate can be moved by arrow-keys or direct input of the testlength.



# Spring tester AFP-6D

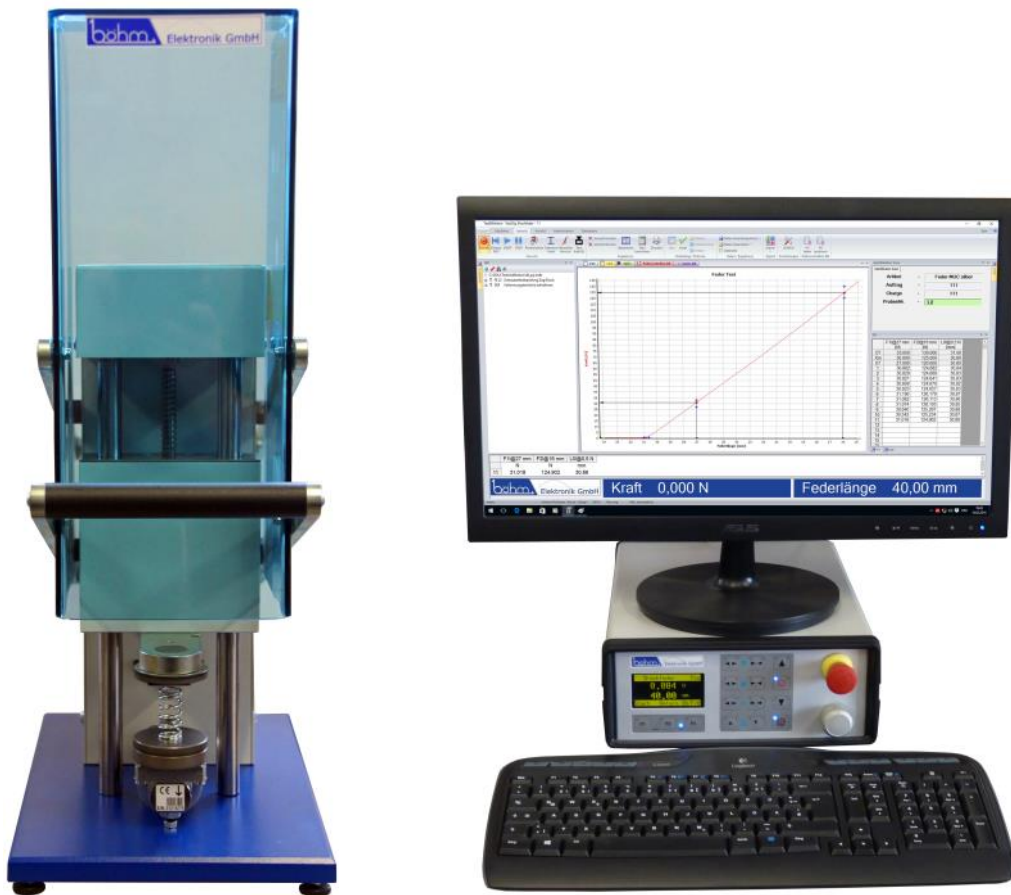

**Automatic spring tester AFP-6D for dynamic or static tests available with specified load ranges:**

Load range 0 - 50 Newton	Resolution: 0,001 N
Load range 0 - 100 Newton	Resolution: 0,001 N
Load range 0 - 200 Newton	Resolution: 0,001 N

Also available with other load cells.

Max. length for compress springs 100 mm. Max. length for tension springs 60 mm.

Automatic Springtester AFP-6D for dynamic or static tests of compression or tension springs. The tester has a rigid load frame with two guide bars and one precision ballscrew. Testplates dia. 45 mm. It can perform various test sequences either length regulated, load regulated or combined. Tests of free length, blocklength, load at length, length at load, rate, load/length and rate/length diagramm are possible.

The results can be archived or exported in Excel format to other CAQ systems.

# Spring tester AFP-7D

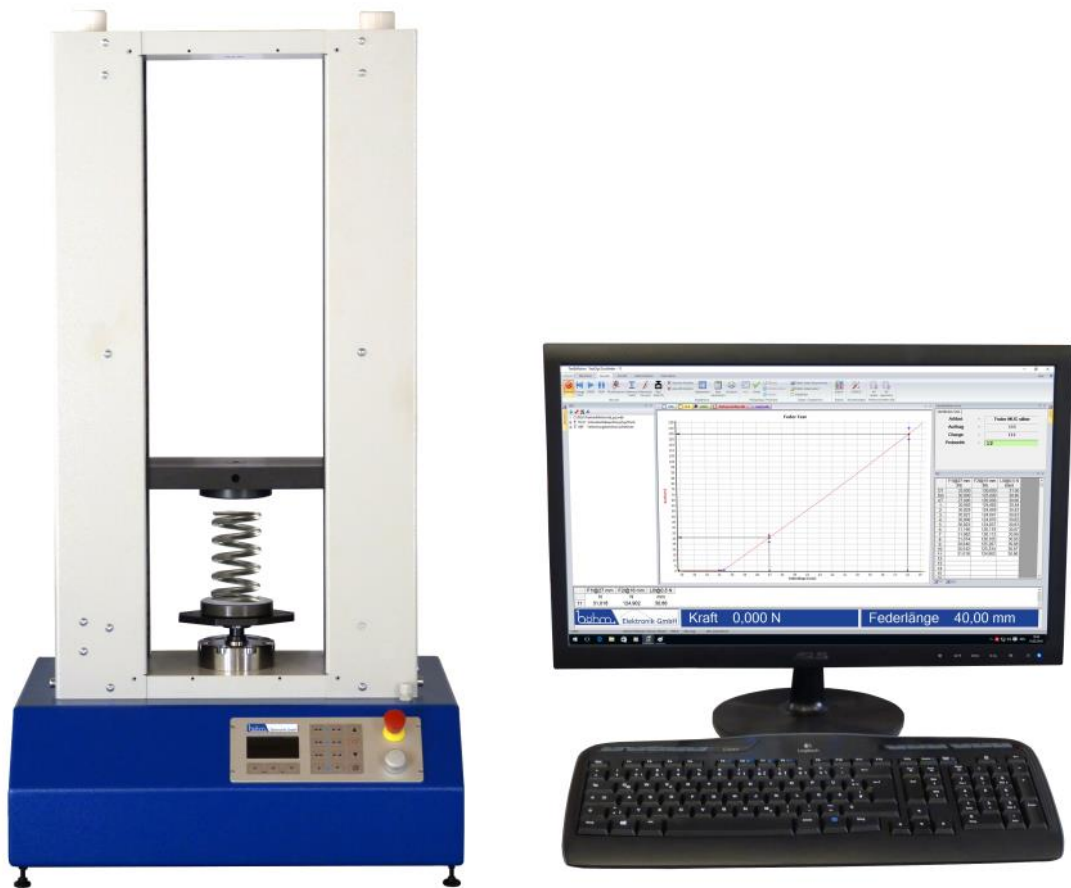

## Automatic spring tester AFP-7D for dynamic or static tests available with specified load ranges:

Load range 0 - 1.000 Newton	Resolution: 0,01 N
Load range 0 - 2.000 Newton	Resolution: 0,01 N
Load range 0 - 5.000 Newton	Resolution: 0,1 N

Also available with other load cells.

Max. length for compress springs 570 mm. Max. length for tension springs 490 mm.

Automatic Springtester AFP-7D for dynamic or static tests of compression or tension springs. The tester has a rigid load frame with two guide bars and two precision ballscrews. Testplates dia. 95 mm or 150 mm. It can perform various test sequences either length regulated, load regulated or combined. Tests of free length, blocklength, load at length, length at load, rate, load/length and rate/length diagramm are possible.

The results can be archived or exported in Excel format to other CAQ systems.

# Spring tester AFP-8KD



**Automatic spring tester AFP-8KD for dynamic or static tests  
available with specified load ranges:**

Load range 0 - 10.000 Newton Resolution: 0,1 N  
Load range 0 - 20.000 Newton Resolution: 0,1 N

Also available with other load cells.

Max. length for compress springs 770 mm. Max. length for tension springs 670 mm.

Automatic Springtester AFP-8KD for dynamic or static tests of compression or tension springs. The tester has a rigid load frame with two guide bars and two precision ballscrews. Testplates dia. 250 mm. It can perform various test sequences either length regulated, load regulated or combined. Tests of free length, blocklength, load at length, length at load, rate, load/length and rate/length diagram are possible.

The results can be archived or exported in Excel format to other CAQ systems.

# Spring tester AFP-20D



**Automatic spring tester AFP-20 static and dynamic tests with servo motor available with specified load ranges:**

Load range 0 - 200 kN Resolution: 1 N

Also available with other load cells.  
Max length for compress springs 1.300 mm.

Automatic tester AFP-20 for test of compression springs with servo motor. Two precision ballscrews (diameter 80 mm) and two columns (diameter 80 mm) guarantee an precise and durably movement of the upper testplate, stroke 1.300 mm with a resolution of 0,01 mm, testplate diameter 400 mm with ring marks to place the spring in center. The upper testplate has the possibility to check springs on a guide mandril with max. diameter of 120 mm or can be used without a hole. The lower testplate rests on 4 loadcells to get a very stable and repeatable result. The speed of the upper testplate is adjustable and performs tests of long springs with high speed. A loading table for a spring or guide mandril is placed in front of the lower testplate so that the spring or the mandril with spring can easily be placed on the testplate. Above the table optional a crane can be fitted to place the bigger springs on the loading table or mandril. The mandrils are fixed on their own baseplate. They are placed on the lower testplate and can be pulled out to load the spring.  
Option: Additional loadcell for tension springs.

# Torsiontester TG-8



**Torsiontester TG-8  
available with specified torque ranges:**

Range 0 - 1.000 Nmm    Resolution: 0,01 Nmm  
Range 0 - 2.000 Nmm    Resolution: 0,01 Nmm

Also available with other torque cells.

Torsiontester TG-8 for inspection of left and right coiled torsion springs. Torque and angle on touchscreen. The angle is measured with 3600 steps per turn that gives a resolution of 0.1 degree. Maximum angle is 9999.9 degree. The tester has two stops for two testpositions for batch tests. The TFT Touchscreen unit has a RS 232 data output for the torque and / or angle to connect with a statistic software or SPC system PC based.

# Torsiontester TG-9



**Torsiontester TG-9  
available with specified torque ranges:**

Range 0 - 5.000 Nmm    Resolution: 0,1 Nmm  
Range 0 - 10.000 Nmm    Resolution: 0,1 Nmm

Also available with other torque cells.

Torsiontester TG-9 for inspection of left and right coiled torsion springs. Torque and angle on touchscreen. The angle is measured with 3600 steps per turn that gives a resolution of 0.1 degree. Maximum angle is 9999.9 degree. The tester has two stops for two testpositions for batch tests. The TFT Touchscreen unit has a RS 232 data output for the torque and / or angle to connect with a statistic software or SPC system PC based.

# Torsiontester TG-11



**Torsiontester TG-11  
available with specified torque ranges:**

Range 0 - 150 Nm    Resolution: 0,01 Nm

Also available with other load cells.

Torsiontester TG-11 for inspection of left and right coiled torsion springs. 5 digit torque display and 5 digit angle display. The angle is on display with 3600 steps per round what is a resolution of 0.1 degree. Maximum angle is 9999.9 degree. The tester has two stops for two testpositions for batch tests. The tester has a RS 232 data output for the torque to connect with a statistic computer or SPC system. Max. distance of plates 800 mm.  
Max. diameter 300 mm.

# Torsiontester TG-18D

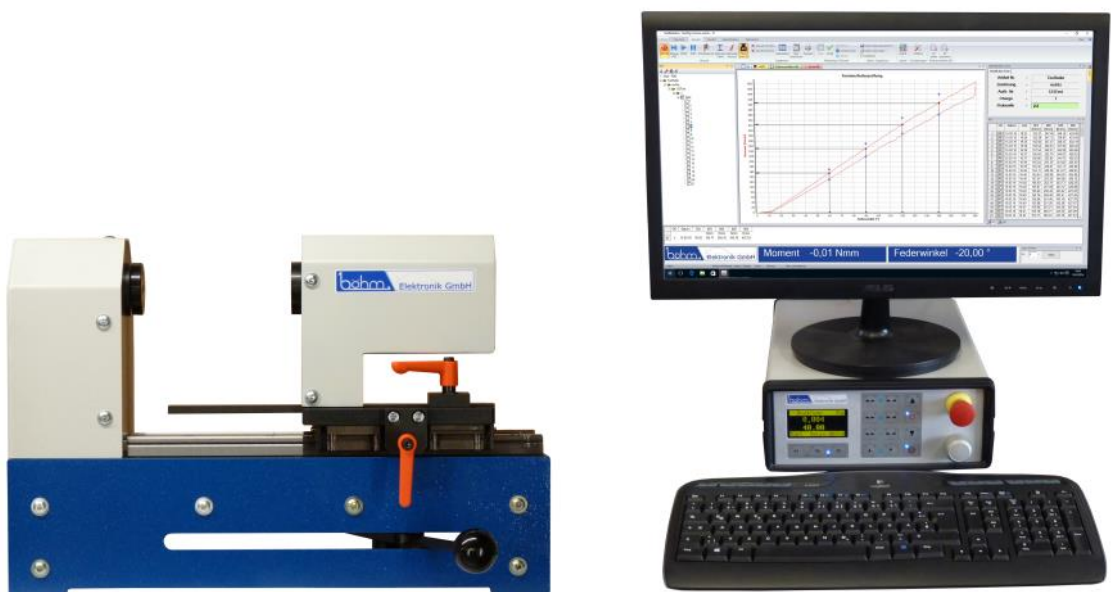

**Automatic torsiontester TG-18D  
available with specified torque ranges:**

Range 0 - 1.000 Nmm Resolution: 0.01 Nmm  
Range 0 - 2.000 Nmm Resolution: 0.01 Nmm

Also available with other load cells.

Automatic torsiontester TG-18D for test of left and right coiled torsion springs. Dynamic or static test of torsion springs. Various tests can be performed at predefinable testspeeds. Torque at angle, springrate, average test between loading and unloading testdirection can be tested from the angle/torque diagram. All tests can be stored. ASCII, EXCEL and WORD export is possible and can be configured on own demands. Auto tara function for torque is built in. Printout with histogram, angle / torque diagram and statistic results is possible.



# Torsiontester TG-19D



## Automatic torsiontester TG-19D available with specified torque ranges:

Range 0 - 5.000 Nmm Resolution: 0.1 Nmm  
Range 0 - 10.000 Nmm Resolution: 0.1 Nmm

Also available with other load cells.

Automatic torsiontester TG-19D for test of left and right coiled torsion springs. Dynamic or static test of torsion springs. Various tests can be performed at predefinable testspeeds. Torque at angle, springrate, average test between loading and unloading testdirection can be tested from the angle/torque diagram. All tests can be stored. ASCII, EXCEL and WORD export is possible and can be configured on own demands. Auto tara function for torque is built in. Printout with histogram, angle / torque diagram and statistic results is possible.

# Torsiontester TG-21

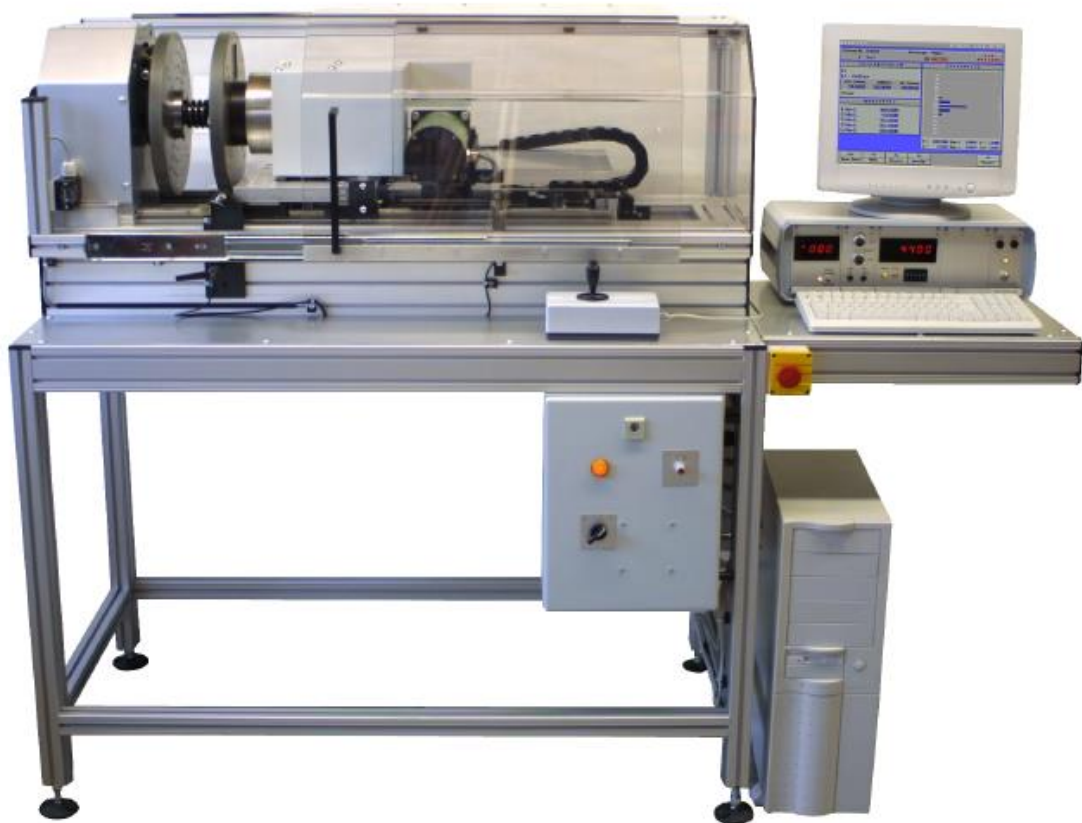

**Automatic torsiontester TG-21  
available with specified torque ranges:**

Range 0 - 19.99 Nm Resolution: 0.01 Nm  
Range 0 - 150.0 Nm Resolution: 0.1 Nm

Also available with other load cells.

Digital reading of tool distance

All functions are controlled by computer. Software contains a database for more than 10.000 types of springs, more than 200.000 testreports of input/output statistics or machine capability reports

Statistic output on laser printer (option) and TFT color monitor

SPC-Software for process control

Other torque ranges on demand.

The angle is on display with 3600 steps per round what is a resolution of 0.1 degree. Maximum angle is 9999.9 degree.

# Automatic prestressing and testing machine SP



## **Automatic prestressing and testing machine SP-1**

Load range 0 - 100 Newton, Resolution: 0,003 N, max. setting load 100 N.

## **Automatic prestressing and testing machine SP-2**

Load range 0 - 1.000 Newton, Resolution: 0,03 N, max. setting load 1.000 N.

Also available with other load cells.

Max. spring length 80 mm, max. spring dia 28 mm. Max. speed 3.500 parts per hour.

A prestressing machine with automatic feeder and load measuring for one spring length and three-way sorting. Measuring of free length and block is optionally available.

The vibratory feeder brings the springs in a vertical tube. A feed device even lets one spring pass the tube and feeds a round transport table which has six holes to hold the testing parts and gets moved step-by-step in clockwise direction. Having passed the feeder the springs are moved to the certain prestressing units followed by a measuring unit with an adjustable in-feed length. Having passed all the units the springs are sorted in three or five definable groups.

# Automatic prestressing and testing machine SM-D

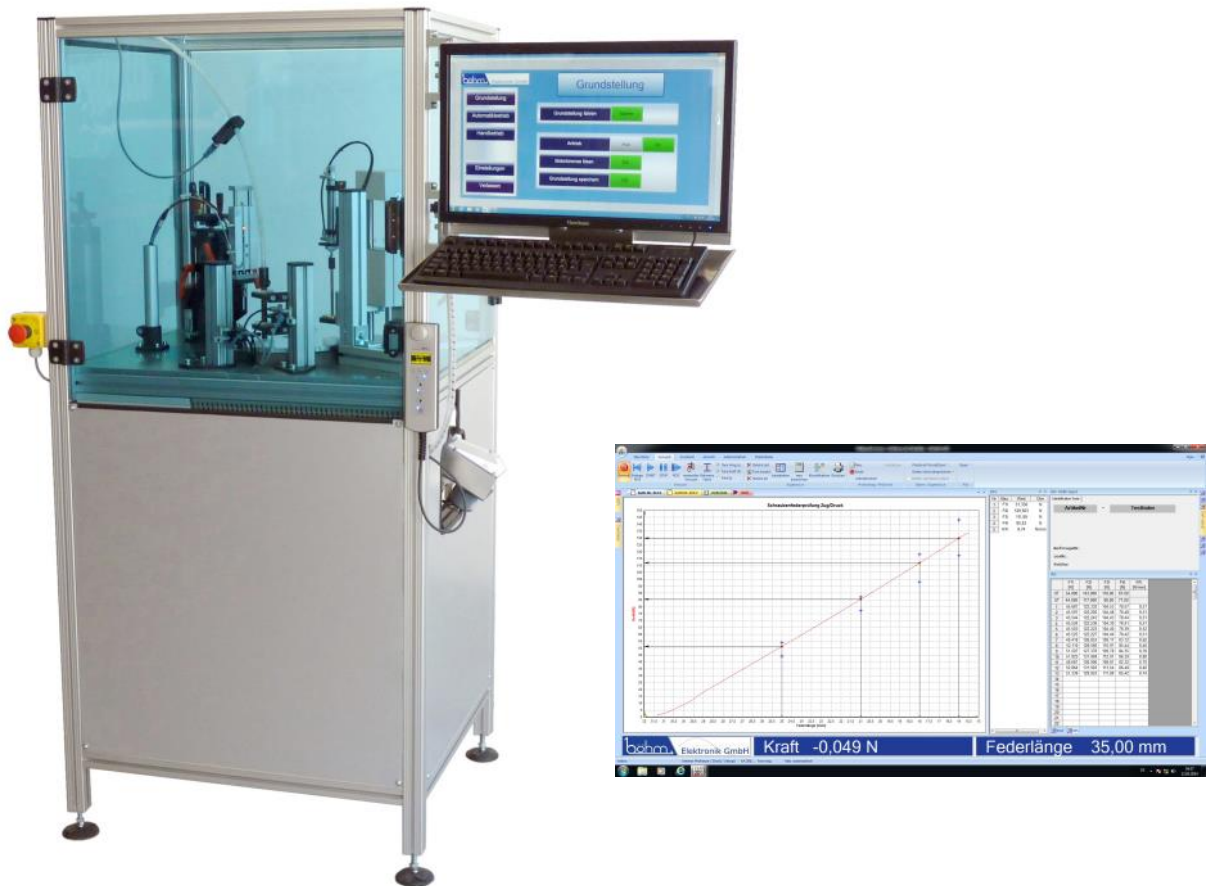

## **Automatic prestressing and testing machine SM-1D**

Load range 0 - 100 Newton, Resolution: 0,001 N. Max. setting load 100 N.

## **Automatic prestressing and testing machine SM-2D**

Load range 0 - 1.000 Newton, Resolution: 0,01 N. Max. setting load 1.000 N.

Also available with other load cells.

Max. spring length 80 mm, max. spring dia 28 mm. Max. speed 3.000 parts per hour.

The vibratory feeder brings the springs in a vertical tube. A feed device even lets one spring pass the tube and feeds a round transport table which has six holes to hold the testing parts and gets moved step-by-step in clockwise direction. Having passed the feeder the springs are moved to the certain prestressing units followed by a measuring unit. Having passed all the units the springs are sorted in three or five definable groups.

The tester has a rigid load frame with two guide bars and two precision ballscrews. It can perform various test sequences either length regulated, load regulated or combined. Tests of free length, blocklength, load at length, length at load, rate, load/length and rate/length diagramm are possible. The results can be archived or exported in Excel format to other CAQ systems.

# Automatic prestressing and testing machine SP-5

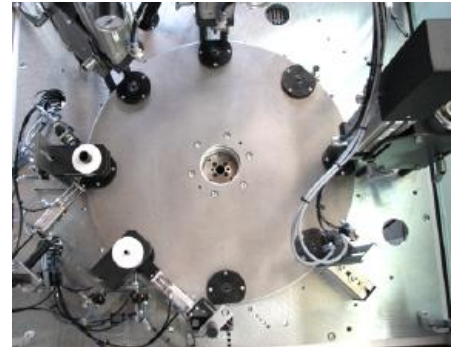

## **Automatic prestressing and testing machine SP-5**

Load range 0 - 5.000 Newton, Resolution: 0,1 N, Max. setting load 5.000 N

Also available with other load cells.

Max. spring length 100 mm, spring dia. 50 mm. Max. speed 2.500 parts per hour

Prestressing machine with automatic feeder or feeding by hand and load measuring for one spring length and three-way or five-way sorting. There are three prestressing units mountable. Measuring of free-length and block is optionally available.

A vibratory feeder or manual feeding brings the springs in a vertical tube. A feed device even lets one spring pass the tube and feeds a round transport table which has eight holes to hold the testing parts and moves step-by-step in clockwise direction. Having passed the feeder the springs are moved to the certain prestressing units followed by a measuring unit with an adjustable in-feed length. Having passed all the units the springs are sorted in three or five definable groups.

# Springcoiler FWM-1



## Compress Spring Coiling Machine

Compact, closed machine frame with integrated electronic motor drive and controls. Touch panel at movable lever for programming and controlling. Prepared for optional double pair of feed rolls. Protecting door included. Several functions can be activated just by keystroke, like: gauge, double cut, linked mode, mandrel movement, sensing mode.

Technical Data:	power supply	400 V
	power consumption	2,5 kW
	wire diameter	0,1 - 0,8 mm
	max. Outside spring diameter	14 mm
	max. Wire feed	30 m
	max. Speed of wirefeed	113 m/min.
	max. Productionspeed	250 springs/min.
	temperature range	+10°C to +40°C

# Grindingmaschine FSA-2



## To produce and grind springs in one operational step

For the automatic production of grinded compression springs, through feed grinding with CBN grinding wheels and step by step loading plate.

**This grinding machine can be coupled directly with a spring coiling machine.**

Technical Data:	grinding wheel diameter	250 mm
	max. Cutting speed	50 m/sec.
	loading plate diameter	225 mm
	max. Spring L0	100 mm
	min. Spring L0	1,25 x spring dia
	max. Grinding capacity	80 springs/min.
	wire diameter	0,3-1,2 mm
	max. Spring De	10 mm
	60 holes single-row	separation 6°

For larger diameters the loading plate has to be manufactured with a different pitch.

# Grindingmachine FSA-3



## To produce and grind springs in one operational step

For the automatic production of grinded compression springs, through feed or in feed grinding with CBN grinding wheels and step by step loading plate.

**This grinding machine can be coupled directly with a spring coiling machine.**

Technical Data:	grinding wheel diameter	400 mm
	max. Cutting speed	75 m/sec.
	loading plate diameter	420 mm
	wire diameter	0,8-1,6 mm through feed grinding
	wire diameter	0,8-2,5 mm in feed grinding
	max. Spring De	30 mm
	max. Spring L0	180 mm
	min. Spring L0	1,25 x spring dia
	max. Grinding capacity	35 springs/min with the big loading device
	max. Grinding capacity	50 springs/min with the small loading device



# Plastic sheet wrapping machine FV-1



## **Plastic sheet wrapping machine FV-1**

Seals individual springs in plastic sheet

The springs are produced in cycles by a spring coiling machine and transferred to the wrapping machine. They are individually sealed between two plastic sheets in a transverse position and conveyed downwards in cycles.

The sealed springs can be wound into spools between two flanges, e.g. with a BAH-1 continuous coiling machine.

Wrapping machine dimensions: W x D x H: 800 x 550 x 1500

Capacity: Up to approx. 3600 springs per hour, depending on spring type.

# Tray packing WP



## Automatic Traypacking Machine WP-1, WP-2

The empty honeycomb packing cases are put in manual as pile in the equipment. A gripper takes one empty packing case off the pile and places it on a transport belt. Every comb of the honeycomb packing case is filled with a part. At the end of the transport strip a gripper piles up the filled honeycomb packing cases. Then the filled cases can be taken away manual as a pile.

Dimensions of the feeding device WP-1:

Width: 1100 mm, Depth: 1000 mm, Height: 1300 mm.

Dimension of the honeycomb packing case: max. 300 x 200 mm

Cycle time of feeding: max. 60 cycles / min.

Height of the piles: max. 580 mm

Dimensions of the feeding device WP-2:

Width: 2270 mm, Depth: 1400 mm, Height: 1750 mm.

Dimension of the honeycomb packing case: max. 600 x 400 mm

Cycle time of feeding: max. 60 cycles / min.

Height of the piles: max. 1000 mm

# Small article storage magazine



## **Small article storage magazine**

Box dimensions width 210 mm, depth 340 mm, height 150 mm, ( other dimensions possible).In this storage magazine 8 boxes are placed which are filled one after the other by a production machine. The amount of filling can be defined by variable time or number of pieces.

The advantages:

Longer production intervals without manual change of boxes enhance the efficiency of production.

The distributor is moveable, the boxes are fix so that you are independent of the weight of the full boxes. In each box the desired number of parts can be produced. In case of problems in the production or bad produced parts not the whole production lot has to be checked; only the effected boxes. The storage magazine is mounted on wheels and is mobile, so that it can be placed at each production machine when necessary.

# Robot loading Device RB



## Loading device for cycled loading plates with robot UR-3 and 5

Rapid reaction and conversion times can be realized with the loading device model RB. This makes the automatic loading of grinding machines also interesting for small and medium-sized quantities. The springs are separated by an integrated drum conveyor model TF with linear feeders. The loading is done directly via a handling robot. Easy and intuitive handling of the robot by direct "teaching" of the robot positions. The handling robot can carry weights of max 3 and 5 kg, and has a working radius of 500 mm. The number of tracks is two by default. More tracks are possible. The integrated drum conveyors can feed springs with diameter of max. TF300 6mm, TF450 12/24mm or TF650 34mm.

# Robot loading Device RB-5

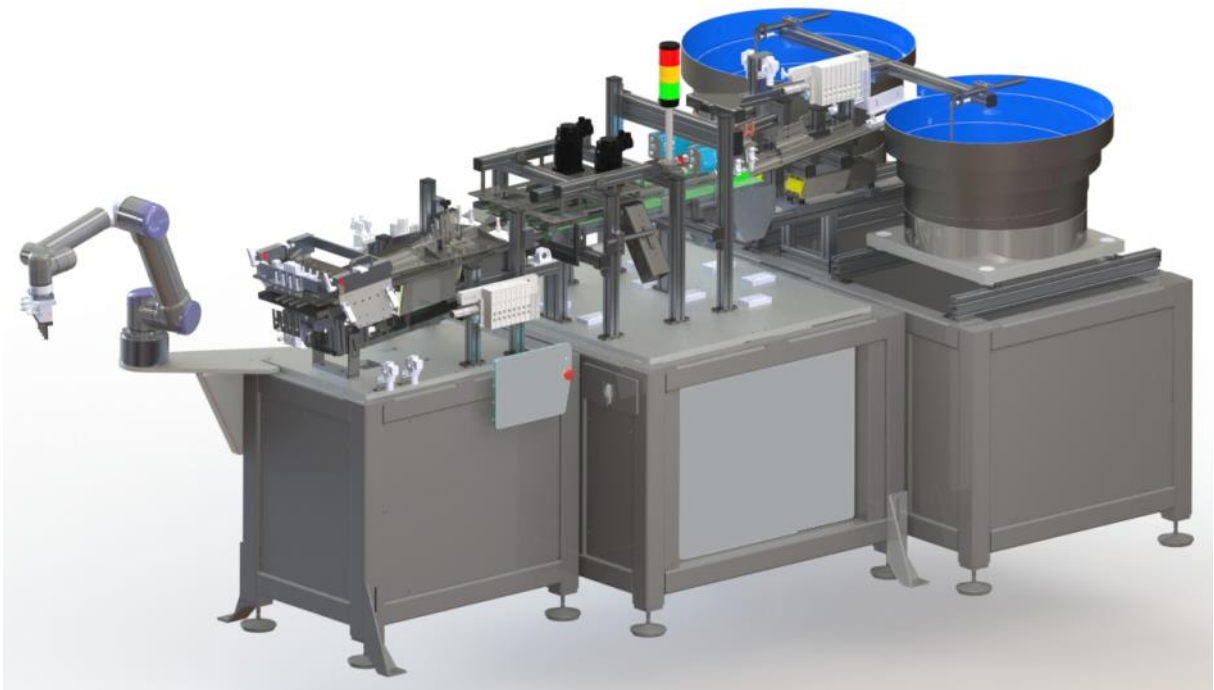

## Loading device for in feed grinding with robot UR-5

Rapid reaction and conversion times can be realized with the loading device model RB-5. This makes automatic loading of grinding machines also interesting for small and medium sized quantities. The springs are separated by two integrated bowl feeders. The loading is done directly via a handling robot. Easy and intuitive handling of the robot by direct "teaching" of the robot positions. The handling robot can carry weights of max. 5 kg and have a working radius of 800mm. Feeding of conical springs in correct positions is possible with camera sensor. The number of tracks is four by default. More tracks are possible. The integrated bowlfeeders WFL 600, can feed springs with max. length 150mm and diameters up to De 26mm.

# Axial conveyor LFA

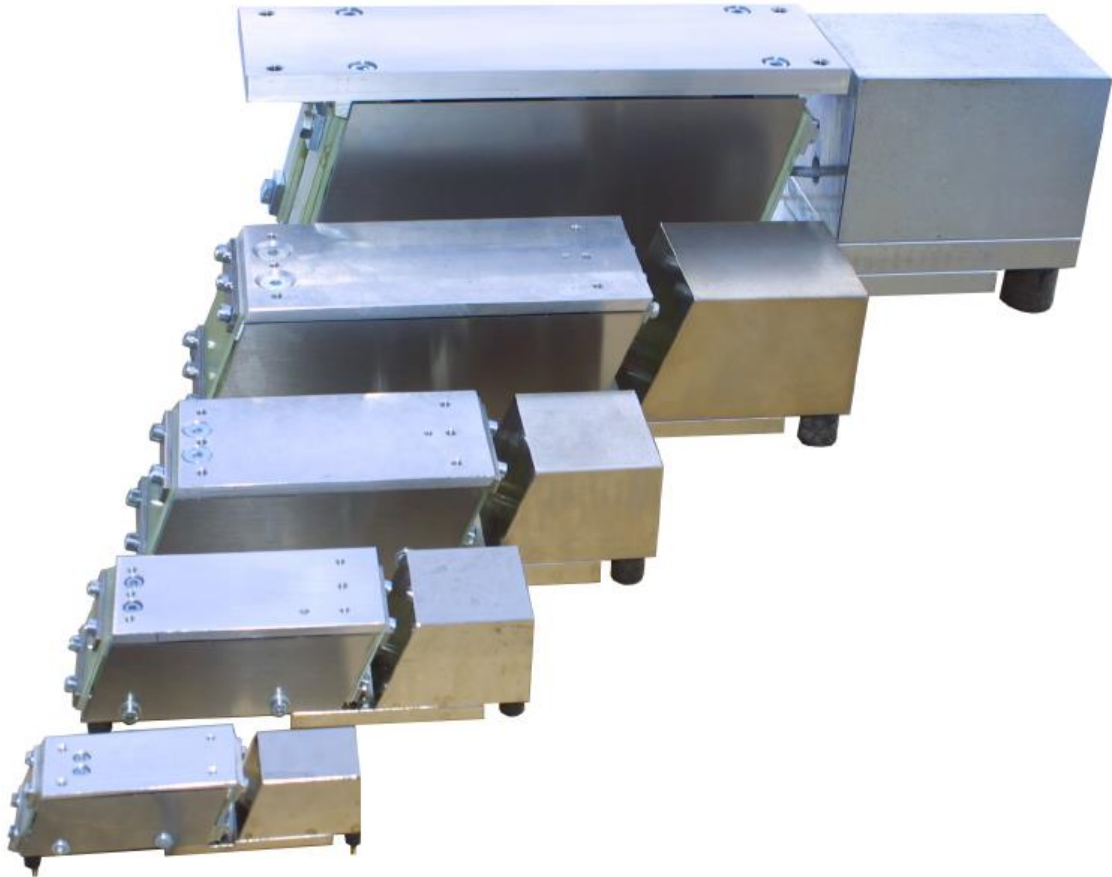

## **Conveyor for feeding parts in one direction**

All five available sizes have an adjustable vibrating system to adapt the system to feeding-rail of different weights without changing parts.

The conveyors LFA 1 - LFA 4 are usable with an inverter or any motor phase control at mains power 230V, 50Hz.

The conveyor LFA 5 has to be supplied with 25 Hz.

# Bowlfeeder driving units WFL

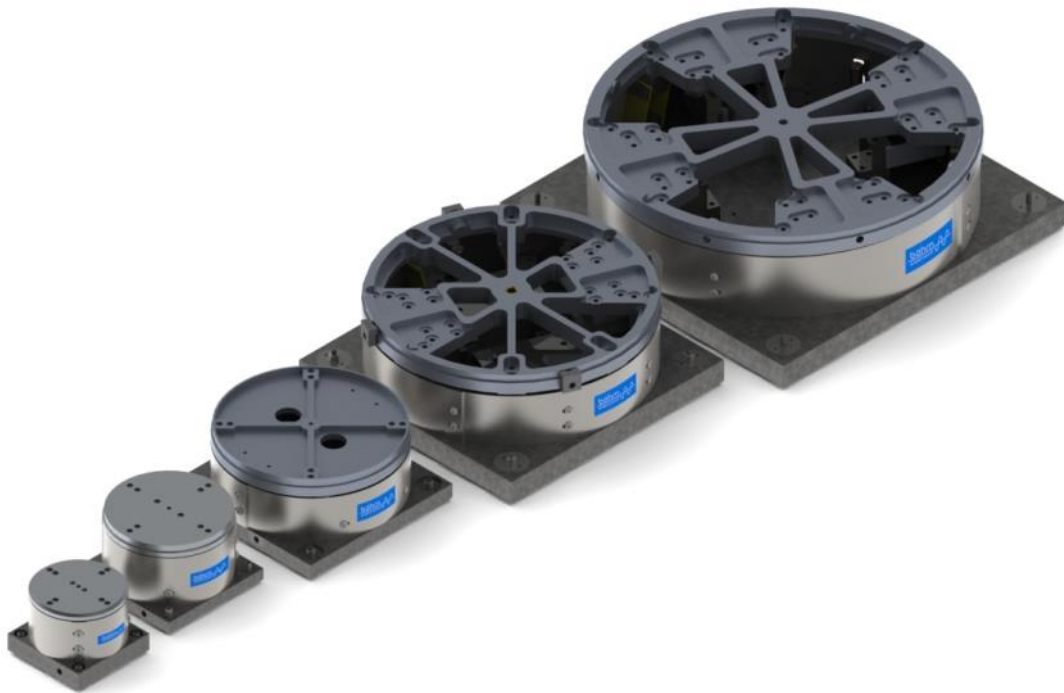

## Vibratory Drives

The advantages of these vibratory drives:

Very low height. Squarely groundplate. The placement of rubber fixingpoints. With these rubber fixations the drives can compensate a higher weight of parts in the bowl. These rubber fixations have fine threads to adjust the height of the vibratory drive or bowl to other components

WFL 150 diameter 150 mm  
 WFL 200 diameter 200 mm  
 WFL 300 diameter 300 mm  
 WFL 450 diameter 450 mm  
 power 230V / 50 Hz

WFL 450 diameter 450 mm  
 WFL 600 diameter 600 mm  
 power 230V, 50 Hz / 25Hz

# Drum Feeder TF



## Spring feeding by drum feeder

This drum feeder is for detangling and separation of springs or other round parts. From a bulk of goods the single parts are positioned in a longitudinal plane and afterwards transported to an automatic feeding station of a spring grinder, scragg and testing machine or a mounting station in a production line. The turning speed of the drum and the feeding speed of the integrated conveyor can be regulated at the control unit.

There are 3 different sizes of drums: TF 300, outside dia. of drum 300 mm, spring De 6 mm.  
TF 450, outside dia. of drum 450 mm, spring De 12/24 mm.  
TF 650, outside dia. of drum 650 mm, spring De 34 mm.



# Vibrator Bowl FZ



## Spring feeding by vibrator bowl

In a vibrator bowl are springs which move by vibrations on spirals to the exit on top. To avoid that more than one spring is transported to the exit there is an adjustable chicane integrated. The feeding speed can be regulated electronically. Because springs have the bad behavior to tangle they may pass the chicane. To avoid that tangled springs reach the exit there is a sensor. This sensor detects single springs or tangled springs. That the sensor can detect single or double springs with small wire diameter as well the sensor must have an adjustable distance to the springs. To adjust easily the distance to the spring a micrometer screw is fixed at the end of the sensor. To find the correct distance a lightband composed of ten LED segments is used as tuning aid. The correct distance to let only pass one single spring can be adjusted by the distance to the spring and the zero signal of the sensor. When two hooked springs pass the sensor the electrical output of the sensor rises and an indicator light flashes. At the same time a pneumatic valve is opened and an airblast blows the tangled springs off the feeding system and back into the vibrator bowl. Only single springs reach the exit of the vibrator bowl. A ringsensor can indicate whether springs should be feed in the following stock tube or whether it is full. As soon as the storage tube is full a yellow lamp flashes to indicate „storage full“ and the vibrator bowl is switched off.

There are 3 different sizes of bowls: FZ - 200, vibrator dia. 200 mm, springs de 2 mm to 6 mm.  
 FZ - 300, vibrator dia. 300 mm, springs de 4 mm to 12 mm.  
 FZ - 450, vibrator dia. 450 mm, springs de 10 mm to 30 mm.

# Spring Detangler FEW



## Springs untangling and feeding

With the integrated detangler springs which were up to now impossible to process automatically can be feed in spring grinders, scragg and testing machines or automatic mounting stations in a production line. With this spring detangler and feeder you have the possibility to change over to a different spring-type without changing parts. You have only to adjust the tangle sensor and the separator that it fits for the required diameter of spring. It can be used with cylindrical, conical and barrel shape compression springs. To handle other shapes or dimensions of parts please contact us. Possibly simple changes of the system can enable the detangling of these parts as well.

Description of function:

The springs are filled into the vibrator feeder bowl manual or over a storage bunker. The vibration moves the springs over the feeding spirals to an adjustable chicane at the top of the bowl which pre-sorts the springs. Afterwards the springs pass a sensor which detects tangled springs. Tangled springs are rejected by an airblast and fall back into the bowl where they are detangled and supplied again over the spirals to the sensor. Detangled springs leave the detangler and can be filled in a tube or can be transported over linear conveyors to the following machine.

There are 3 different sizes of bowls: FEW - 200, vibrator dia. 200mm, springs de 2 mm to 6 mm.  
FEW - 300, vibrator dia. 300mm, springs de 4 mm to 12 mm.  
FEW - 450, vibrator dia. 450mm, springs de 10 mm to 30 mm.

# Feeding System by Camera



**Springs and other parts, feeding and untangling by camera FEW 200K, FEW 300K, FEW 450K.**

Part / No Part Detection  
Completeness Check of Construction units/- groups  
Check for correct feeding position  
Check for Tangled Springs  
Examine for sort purity

Stand-Alone Solution (PC is only required for configuration of inspections).

20 Inspektios / different parts possible.

Max. Dimension of part to be checked 25 x 80 mm.

Max. No. of pieces: depends on parts to be checked and No. of characteristics max. 120 / min

# Storage hoppers VB



## **Provision of parts for feed systems of bulk goods of all kinds**

Storage hoppers with electromagnetic drive

The bulk goods are tipped into the storage container. A control unit adjusts the desired conveying rate by means of an electromagnetic drive system. The storage hopper can be automatically switched on or off by a contents level monitor in the feed system.

Additional equipment:

Control unit , contents level monitors for feed systems, base frame for the storage hopper.

Capacities:

VB - 06,	up to 6 litres,	max. 3 kg
VB - 20,	up to 20 litres,	max. 10 kg
VB - 40,	up to 40 litres,	max. 25 kg
VB - 80,	up to 80 litres,	max. 50 kg

# Detangler EW-1



## **Springs untangling by a detangler**

With the detangler EW 1 it is possible to detangle parts which could not be detangled before. For cylindrical or conical compression springs. The springs are filled manual into the detangler. The rotation of the wheel in the detangler make an air cushion. This air cushion blows the detangled springs on top into a container. There the springs can be taken away.

For an optimal detangling of the different springs the rotation speed of the detangler wheel can be varied with a speed regulator.

outside diameter:	appr. 2 mm - 10 mm
length:	appr. 35 mm
diameter of wire:	appr. 0,3 mm - 1,0 mm

Max. filling capacity 0,1 l | dependent on form and size of the spring.

# Conveyor belt SVB 80



## Conveyor belt SVB80 with storage hopper

The springs are filled in as bulk material. The springs move proportioned to the conveyor belt and move to the top.

Technical data:	beltwide	240 mm
	belthigh	2000 mm
	storage hopper high	900 mm
	capacity	appr. 80 litres, max. 80 kg

# Swift AGH-1.5/B



## Swift AGH-1.5/B for wire rings or drums

On the swift AGH-1.5/B the wire can be placed horizontal on rings or drums. The swift is designed for continuous wirefeed as well as for intermittent wirefeed. Because of the electronic controlled motor with tensioncontrol the swift guarantees low and to the wire diameter adaptable tensionforces. Beside this there are no additional radialforces on the wirefeed of the coiler. With these advantages you can reach a high accuracy in wirefeed which improves the quality especially on a critical production. Higher production speed of springs can be reached because of the high speed of the swift. The swift has safety barrier connectors and hand-operating device.

Technical data:	power supply	400 V
	power consumption	0,7 kW
	wire diameter	0,6 - 3 mm
	linner diameter of drum or ring	170 - 690 mm
	max. height of drum or ring	150 mm
	max. load of drum or ring	150 kg
	max. speed	100 rpm
	diameter of table	600 or 800 mm

# Swift AGH-1.5/Z



## Swift AGH-1.5/Z for wire rings or drums

On the swift AGH-1.5/Z the wire can be placed horizontal on rings or drums. The swift is designed for continuous wirefeed as well as for intermittent wirefeed. Because of the electronic controlled motor with tensioncontrol the swift guarantees low and to the wire diameter adaptable tensionforces. Beside this there are no additional radialforces on the wirefeed of the coiler. With these advantages you can reach a high accuracy in wirefeed which improves the quality especially on a critical production. Higher production speed of springs can be reached because of the high speed of the swift. The swift has safety barrier connectors and hand-operating device.

Technical data:	power supply	400 V
	power consumption	0,7 kW
	wire diameter	0,1 - 0,6 mm
	linner diameter of drum or ring	170 - 690 mm
	max. height of drum or ring	150 mm
	max. load of drum or ring	150 kg
	max. speed	100 rpm
	diameter of table	600 or 800 mm



# Swift AGH-1.5/BZ



## Swift AGH-1.5/BZ for wire rings or drums

On the swift AGH-1.5/BZ the wire can be placed horizontal on rings or drums. The swift is especially designed for thin wires and features continuous as well as for intermittent wirefeed. Because of the electronic controlled motor with tensioncontrol the swift guarantees low and to the wire diameter adaptable tensionforces. Beside this there are no additional radialforces on the wirefeed of the coiler. With these advantages you can reach a high accuracy in wirefeed which improves the quality especially on a critical production. Higher speed in production of springs can be reached because of the high speed of the swift. Two different wire leading systems are switchable so that smallest wire diameters can be used. The swift has safety barrier connectors and hand-operating device.

Technical data:	power supply	400 V
	power consumption	0,7 kW
	wire diameter	0,1 to 3 mm
	inner diameter of drum or ring	170 - 690 mm
	max. height of drum or ring	150 mm
	max. load of drum or ring	150 kg
	max. speed	100 rpm
	diameter of table	600 or 800 mm

# Swift AGH-2.5



## Swift AGH-2.5 for wire rings or drums

On the swift AGH-2.5 the wire can be placed horizontal on rings or drums. The swift is designed for continuous wirefeed as well as for intermittent wirefeed. Because of the electronic controlled motor with tensioncontrol the swift guarantees low and to the wire diameter adaptable tensionforces. Beside this there are no additional radialforces on the wirefeed of the coiler. With these advantages you can reach a high accuracy in wirefeed which improves the quality especially on a critical production. Higher production speed of springs can be reached because of the high speed of the swift. The swift has safety barrier connectors and hand-operating device.

Technical data:	power supply	400 V
	power consumption	1,5 KW
	wire diameter	0,4 - 1,6 mm
	min. inner dia. of drum or ring	150 mm
	max. load of drum or ring	350 kg
	max. speed	80 rpm
	wire accumulator	3,5 m
	guiding wheels	240 mm or 500 mm
	diameter of table	1000 mm

# Swift AGH-3.5/B

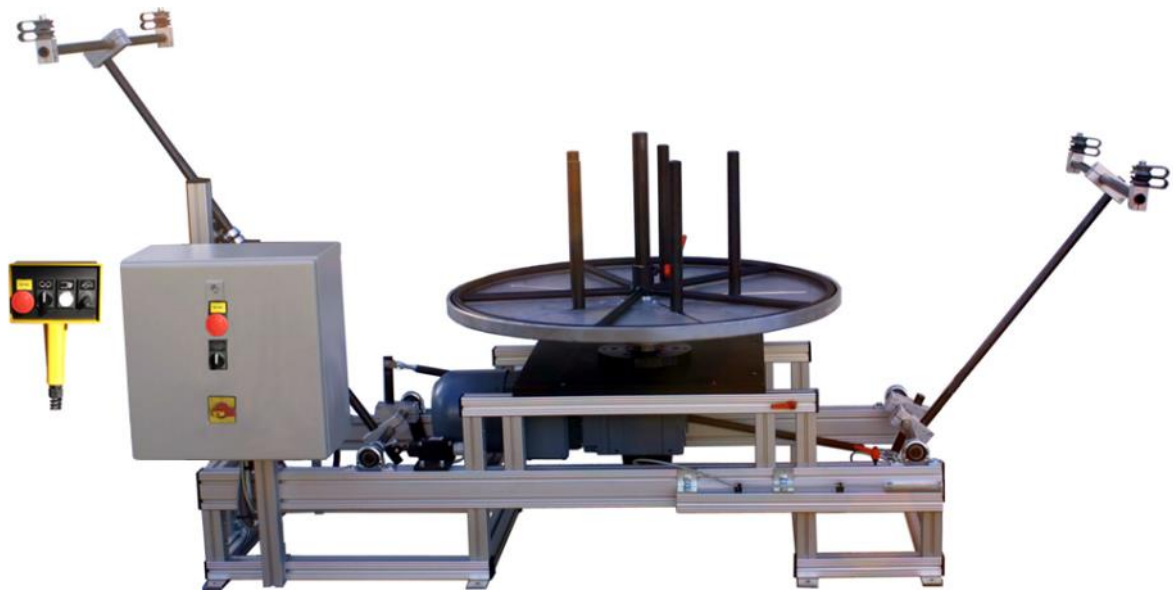

## Swift AGH-3.5/B for wire rings or drums

On the swift AGH-3.5/B the wire can be placed horizontal on rings or drums. The swift is designed for continuous wirefeed as well as for intermittent wirefeed. Because of the electronic controlled motor with tensioncontrol the swift guarantees low and to the wire diameter adaptable tensionforces. Beside this there are no additional radialforces on the wirefeed of the coiler. With these advantages you can reach a high accuracy in wirefeed which improves the quality especially on a critical production. Higher production speed of springs can be reached because of the high speed of the swift. The swift has safety barrier connectors and hand-operating device.

Technical data:	power supply	400 V
	power consumption	1,5 KW
	wire diameter	1 - 3 mm
	min. inner dia. of drum or ring	150 mm
	max. height of drum or ring	240 mm
	max. load of drum or ring	350 kg
	max. speed	90 rpm
	diameter of table	1000 mm

# Swift AGH-3.5/BZ

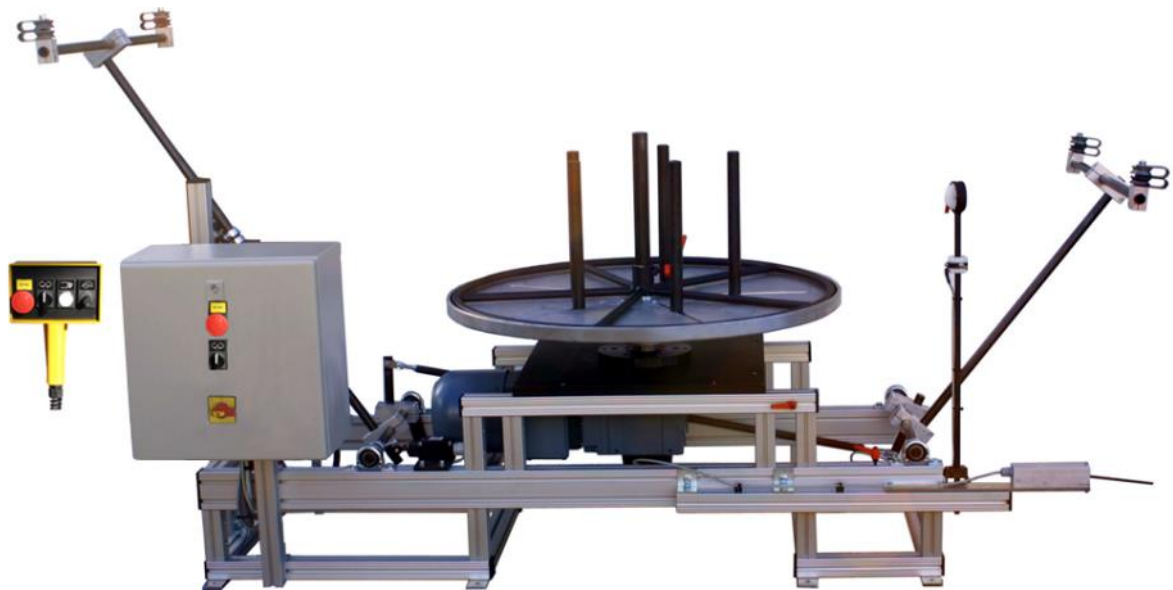

## Swift AGH-3.5/BZ for wire rings or drums

On the swift AGH-3.5/BZ the wire can be placed horizontal on rings or drums. The swift is designed for continuous wirefeed as well as for intermittent wirefeed. Because of the electronic controlled motor with tensioncontrol the swift guarantees low and to the wire diameter adaptable tensionforces. Beside this there are no additional radialforces on the wirefeed of the coiler. With these advantages you can reach a high accuracy in wirefeed which improves the quality especially on a critical production. Higher production speed of springs can be reached because of the high speed of the swift. Two different wire leading systems are switchable so that smallest wire diameters can be used. The swift has safety barrier connectors and hand-operating device.

Technical data:	power supply	400 V
	power consumption	1,5 KW
	wire diameter	0,1 - 3,0 mm
	min. inner dia. of drum or ring	150 mm
	max. height of drum or ring	240 mm
	max. load of drum or ring	350 kg
	max. speed	90 rpm
	diameter of table	1000 mm

# Swift AGH-7.5



## Swift AGH-7.5 for wire rings or drums

On the swift AGH-7.5 the wire can be placed horizontal on rings or drums. The swift is designed for continuous wirefeed as well as for intermittent wirefeed. Because of the electronic controlled motor with tensioncontrol the swift guarantees low and to the wire diameter adaptable tensionforces. Beside this there are no additional radialforces on the wirefeed of the coiler. With these advantages you can reach a high accuracy in wirefeed which improves the quality especially on a critical production. Higher production speed of springs can be reached because of the high speed of the swift. The swift has safety barrier connectors and hand-operating device.

Technical data:	power supply	400 V
	power consumption	1,5 KW
	wire diameter	1,0 - 5,0 mm
	min. inner dia. of drum or ring	300 mm
	max. height of drum or ring	600 mm
	max. load of drum or ring	700 kg
	max. speed	80 rpm
	diameter of table	1200 mm

# Swift AGH-1.5/Z-S

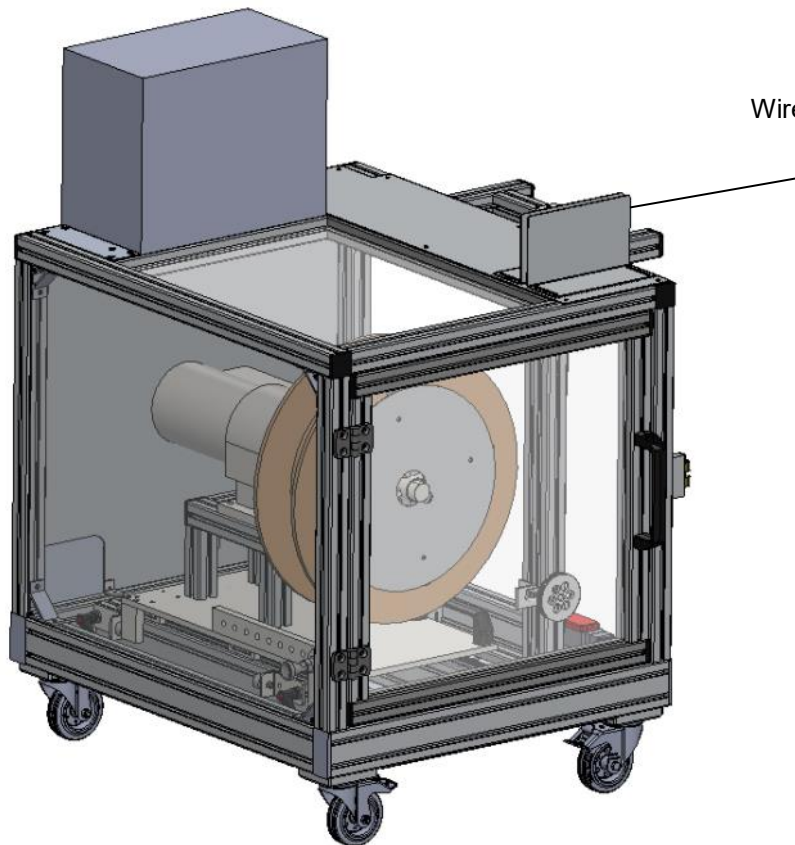

## Swift AGH-1.5/Z-S for wire spools

The swift is best usable in a production with a continuous wire feed to the machine. Because of the motor powered with wire tension control the swift guarantees low and to the wire diameter adaptable tensionforces. Beside this there are no additional radialforces on the wirefeed of the coiler. With these advantages you can reach a high accuracy in wirefeed which improves the quality especially on a critical production. Higher productionspeed of springs can be reached because of the high speed of the swift. The swift has safety barrier connectors and hand-operating device.

The extremely smooth wire guide allows thinnest wires to be processed  
The AGH-1.5/Z-S offers maximum safety through a complete protective housing.

Technical data:	voltage	230V oder 400 - 500V
	power consumption	0,5 KW
	wire diameter	0,1 – 0,6 mm
	spool diameter	app. 460 mm
	core hole diameter	app. 304 mm
	Spool width	app. 200 mm
	max. load of spool	80 kg
	max. speed	100 U/min

# Drum Swift AGH-SP1.5



## Drum swift AGH-SP1.5 for Sandvik and similar wiredrums

The swift is best usable in a production with a continuous wire feed to the machine. Because of the motor powered with wire tension control the swift guarantees low and to the wire diameter adaptable tensionforces. Beside this there are no additional radialforces on the wirefeed of the coiler. With these advantages you can reach a high accuracy in wirefeed which improves the quality especially on a critical production. Higher productionspeed of springs can be reached because of the high speed of the swift. The swift has safety barrier connectors and hand-operating device.

Technical data:	voltage	400 V
	power consumption	0,7 kVA
	wire diameter	0,5 -1,5 mm
	max. drum diameter	760 x 310, 410 or 510 mm
	max. load of drum	300 kg
	max. speed	65 rpm

# Drum Swift AGH-SP3.5



## Drum swift AGH-SP3.5 for Sandvik and similar wiredrums

The swift is best usable in a production with a continuous wire feed to the machine. Because of the motor powered with wire tension control the swift guarantees low and to the wire diameter adaptable tensionforces. Beside this there are no additional radialforces on the wirefeed of the coiler. With these advantages you can reach a high accuracy in wirefeed which improves the quality especially on a critical production. Higher productionspeed of springs can be reached because of the high speed of the swift. The swift has safety barrier connectors and hand-operating device.

Technical data:	voltage	400 V
	power consumption	1,1 kVA
	wire diameter	0,5 -2,5 mm
	max. drum diameter	760 x 510 mm
	max. load of drum	500 kg
	max. speed	80 rpm



# Drum Swift SPH-1000.5 TR

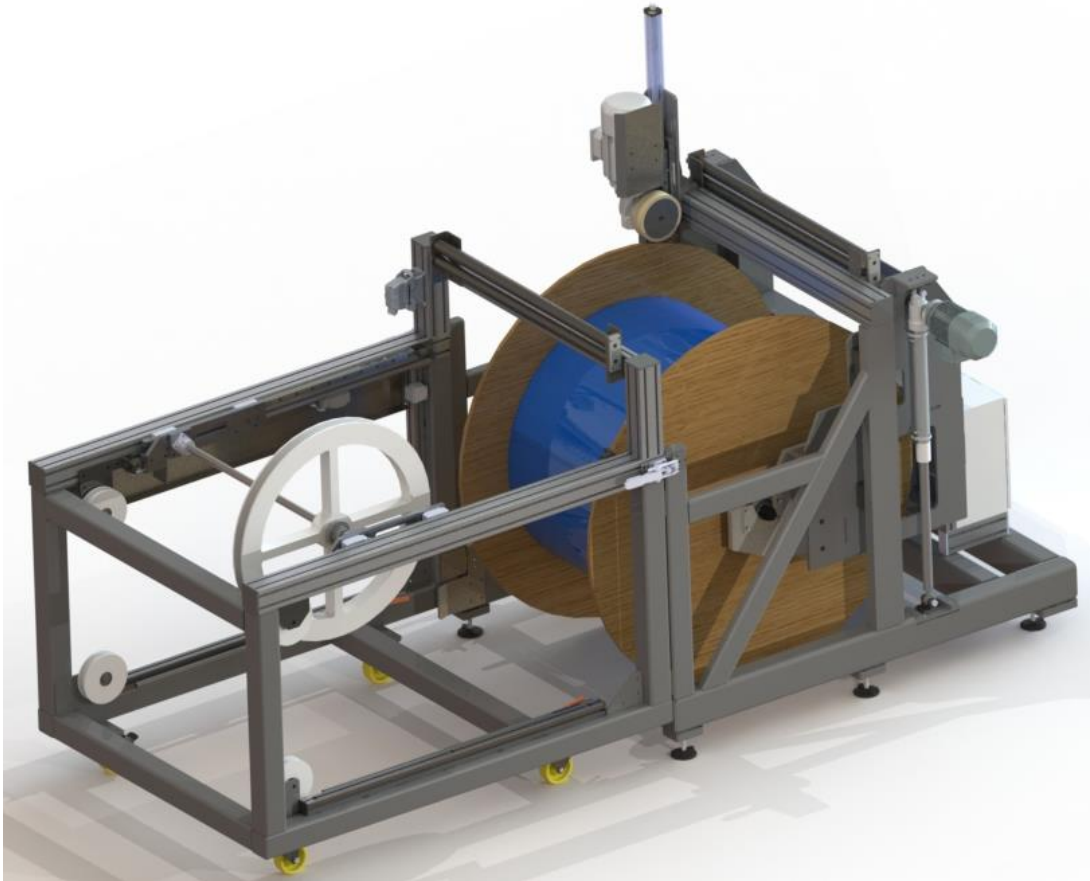

## Drum Swift SPH-1000.5 TR

The swift is best usable in a production with a continuous wire feed to the machine. Because of the motor powered with wire tension control the swift guarantees low and to the wire diameter adaptable tensionforces. Beside this there are no additional radialforces on the wirefeed of the coiler. With these advantages you can reach a high accuracy in wirefeed which improves the quality especially on a critical production. Higher productionspeed of springs can be reached because of the high speed of the swift. The swift has safety barrier connectors and hand-operating device.

The wire spool is driven up and down by an electrical lifting device. The wire guide (dancer wheel) is particularly smooth for sensitive copper wires or narrow flat material.

Technical data:	voltage	400 V
	power consumption	1,5 kVA
	wire diameter	app. 3 - 10 mm
	drum core hole	80 mm
	max. drum width	app. 700 mm
	max. drum diameter	app. 1000 mm
	wire outlet height	app. 1200 - 1400 mm
	max. load of drum	1200 kg
	max. speed	120 m/min

# Drum Swift SPH-1000.5 T

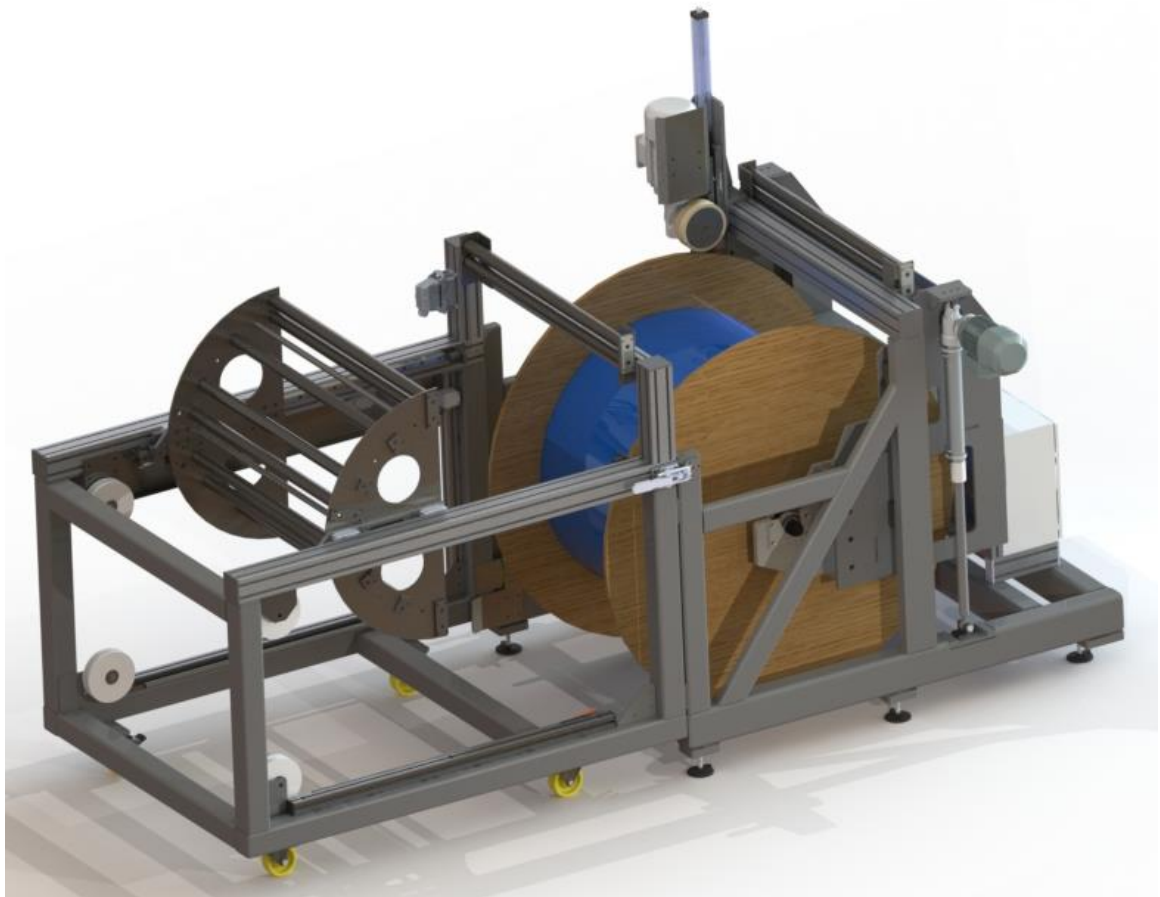

## Drum Swift SPH-1000.5 T

The swift is best usable in a production with a continuous wire feed to the machine. Because of the motor powered with wire tension control the swift guarantees low and to the wire diameter adaptable tensionforces. Beside this there are no additional radialforces on the wirefeed of the coiler. With these advantages you can reach a high accuracy in wirefeed which improves the quality especially on a critical production. Higher productionspeed of springs can be reached because of the high speed of the swift. The swift has safety barrier connectors and hand-operating device.

The wire spool is driven up and down by an electrical lifting device. The wire guide (dancer) is designed for strong copper wires or strong wide flat material.

Technical data:	voltage	400 V
	power consumption	1,5 kVA
	wire diameter	app. 3 - 10 mm
	drum core hole	80 mm
	max. drum width	app. 700 mm
	max. drum diameter	app. 1000 mm
	wire outlet height	app. 1200 - 1400 mm
	max. load of drum	1200 kg
	max. speed	120 m/min

# Flatmaterial Swift BAH-1.5

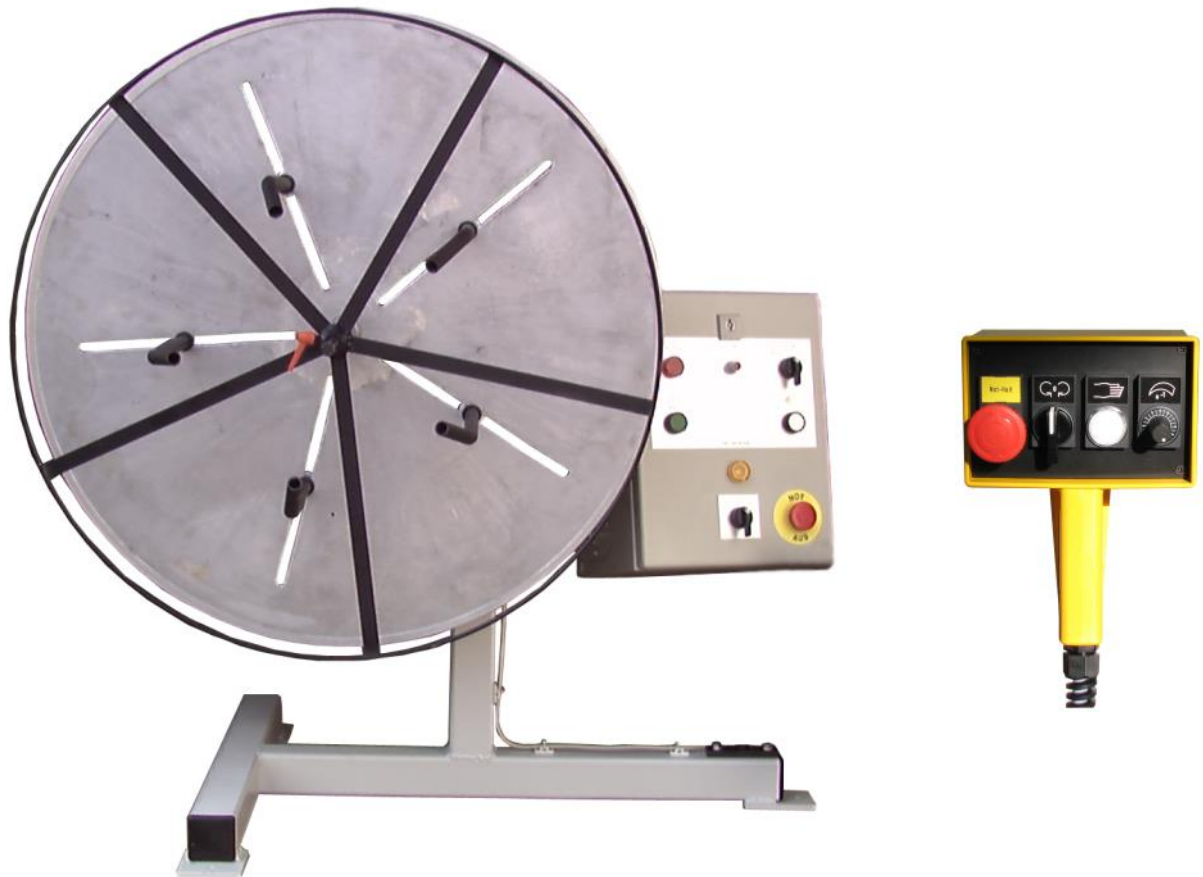

## Swift BAH-1.5 for flatmaterial

This swift is controlled absolutely without any contact of the material to the swift. The material that has to be feeded to the machine runs to a laser sensor. If more material is needed by the machine the flat material is pulled up and the distance to laser sensor is reduced. The swift begins to dewheel the material. The speed of the swift is proportional to the materials distance to the laser sensor. With a regulator the speed can be adapted to the input of the machine. If the machine stops the speed gets reduced till the swift stands still. Flat material min. 30mm works with the laser sensor. Flat material less than 30mm works with a dancer. The swift has safety barrier connectors and hand-operating device.

Technical data:	power supply	400 V
	power consumption	0,7 KW
	flatmaterial ring inner dia	170 - 490 mm
	max. height of ring	100 mm
	max. ring weight	80 kg
	speed	app. 0 - 10 rpm
	diameter of table	600 or 800 mm

# Flatmaterial Swift BAH-1200.5



## Swift BAH-1200.5 for flatmaterial

This swift is controlled absolutely without any contact of the material to the swift. The material that has to be feeded to the machine runs to a laser sensor. If more material is needed by the machine the flat material is pulled up and the distance to laser sensor is reduced. The swift begins to dewheel the material. The speed of the swift is proportional to the materials distance to the laser sensor. With a regulator the speed can be adapted to the input of the machine. If the machine stops the speed gets reduced till the swift stands still. Flat material min. 30mm works with the laser sensor. Flat material less than 30mm works with a dancer. The swift has safety barrier connectors and hand-operating device.

Technical data:	power supply	400 V
	power consumption	0,4 KW, 1,1 KW
	flatmaterial ring inner dia.	350 - 720 mm
	max. height of ring	150 mm
	max. ring weight	600 kg
	speed app. 0 - 13 rpm,	0 - 50 rpm
	diameter of table	1200 mm

# Tempering furnace ROTA-1



## Pulse controlled tempering furnace for ROTA-1

### Method of operation:

The springs are individually inserted into metal tubes up to 160 pieces, two rows (2 x 80 pieces) and passed through the heating chamber in pulsed movements. The advancing and removal processes are performed by compressed air. Electronic temperature regulation by temperature preselection facility.

Electronic control permits fully automatic operation with signal transfer for interlinked operating mode.

Technical data:	connected load	400 V, app. 1,5 KW
	max. tempering temperature	app. 300 °C
	max. pulse rate	app. 50 units per min.

# Tempering furnace ROTA-2



## Pulse controlled tempering furnace for ROTA-2

### Method of operation:

The springs are individually inserted into metal tubes up to 240 pieces, two rows, (2 x 120 pieces) and passed through the heating chamber in pulsed movements. The advancing and removal processes are performed by compressed air. Electronic temperature regulation by temperature preselection facility. Electronic control permits fully automatic operation with signal transfer for interlinked operating mode.

Technical data:	connected load	400 V, app. 2,5 KW
	max. tempering temperature	app. 300 °C
	max. pulse rate	app. 50 units per min.